

Taal: Engels



Handleiding

Merk GYS Lasapparaat CO2 T3
Artikelnummer GY 032958

MSH equipment
Appelmarkt 7
1681 PE Zwaagdijk-Oost
Tel: 0228-561100
Fax: 0228-561112
Mail: info@msh-equipment.nl

Website: www.msh-equipment.nl

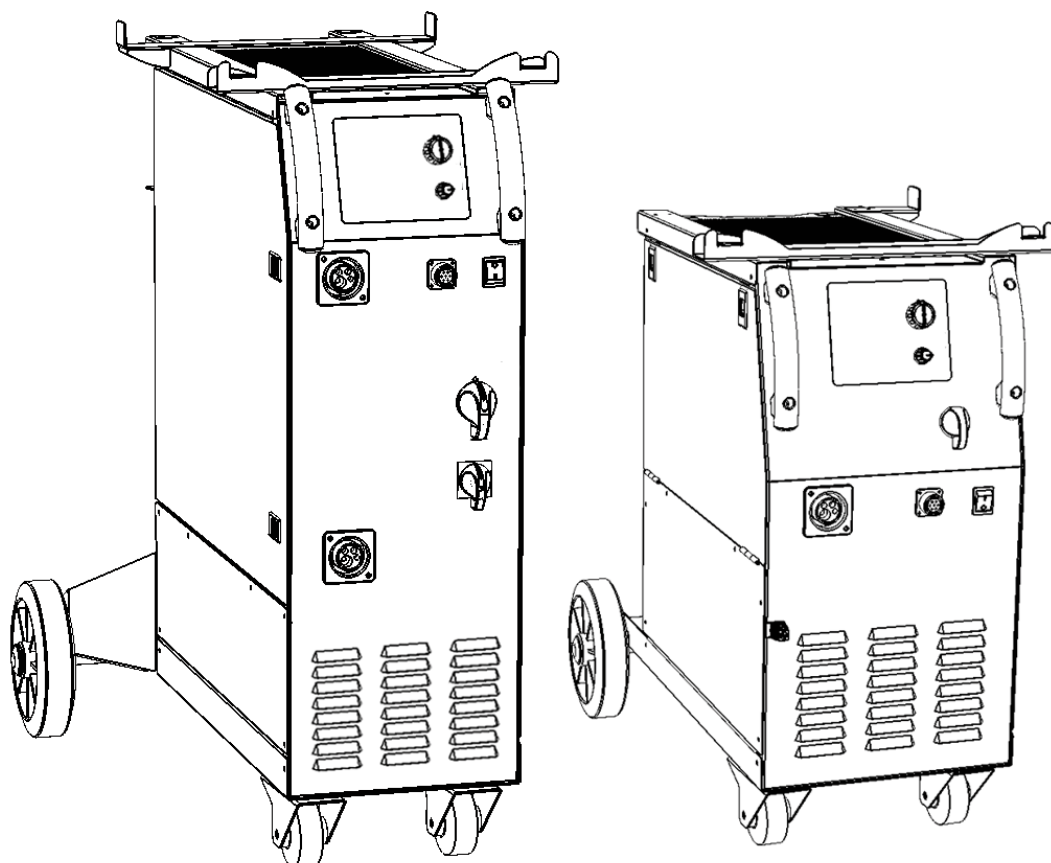

FR 6-10 / 27-36

EN 11-14 / 27-36

DE 15-18 / 27-36

ES 19-22 / 27-36

RU 23-26 / 27-36

M1 GYS AUTO
T1 GYS AUTO
T1 GYS AUTO DV
T3 GYS AUTO
T3 GYS AUTO DV

I - M1 & T1

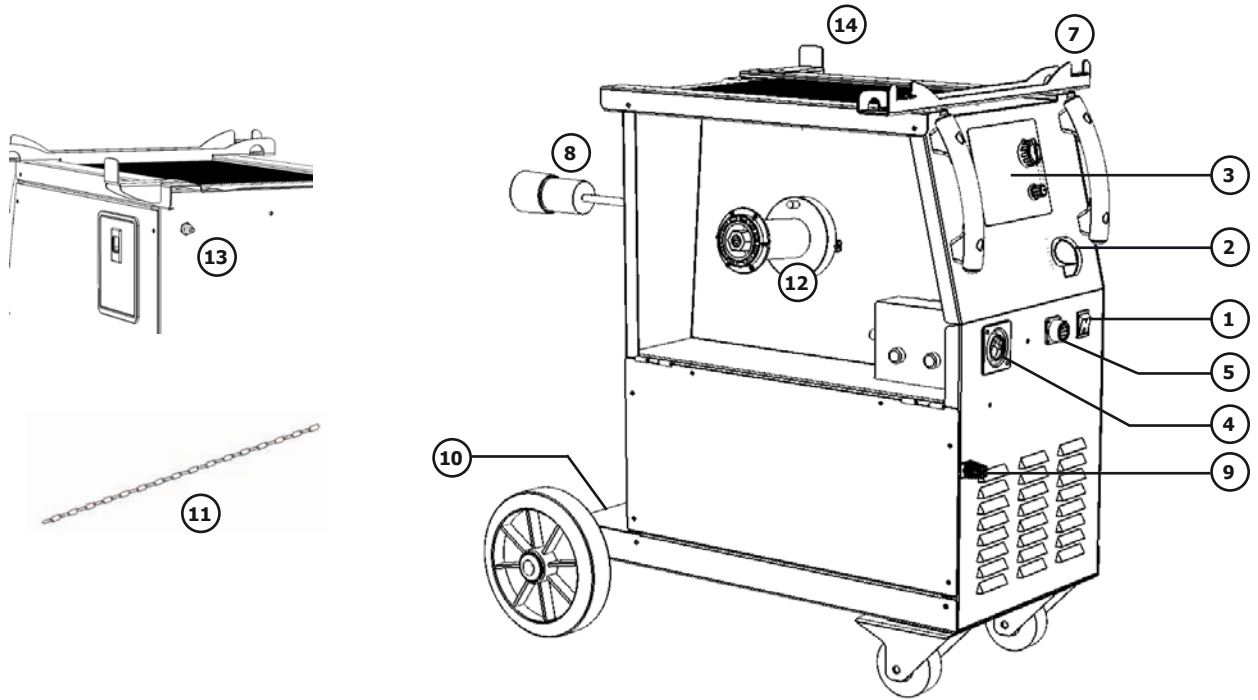

II - T3

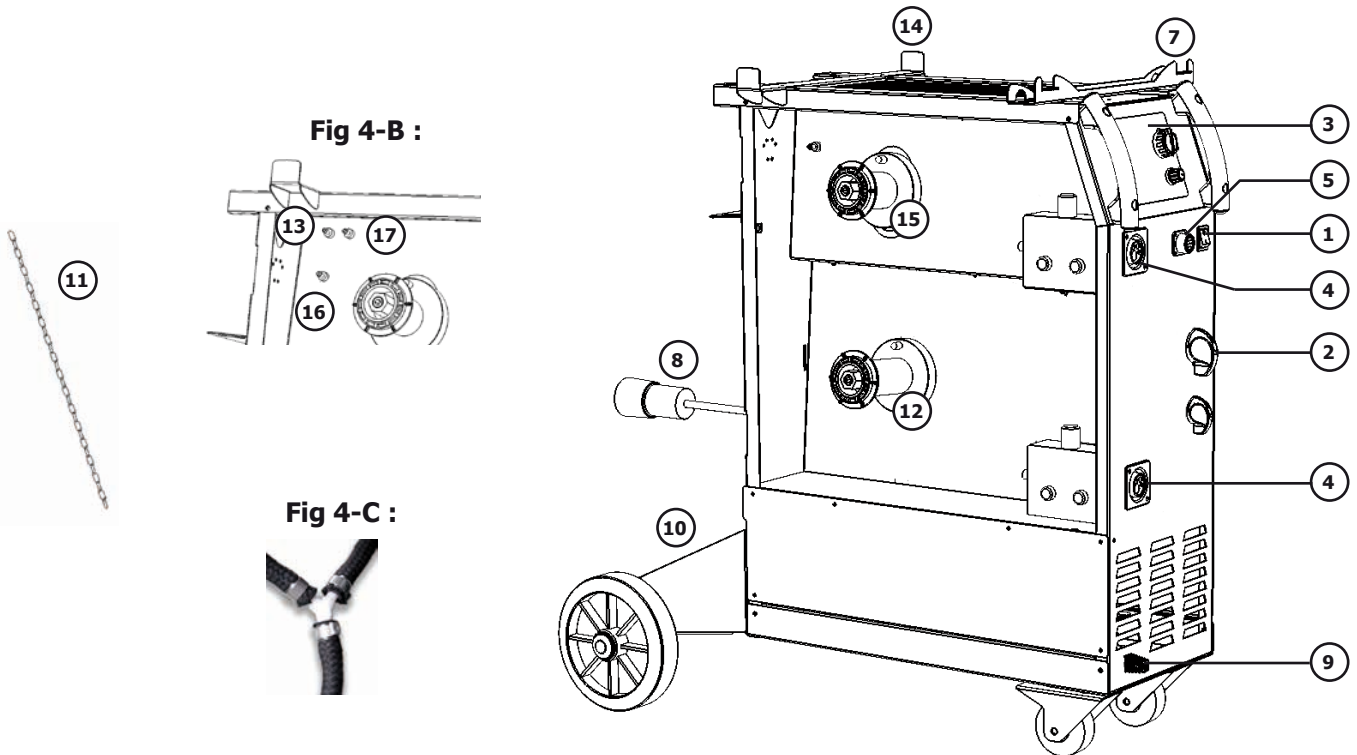

III

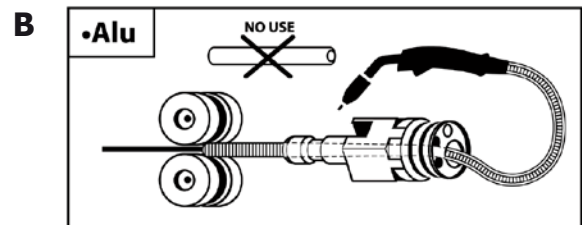
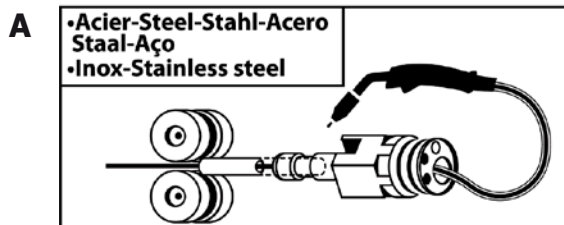

IV

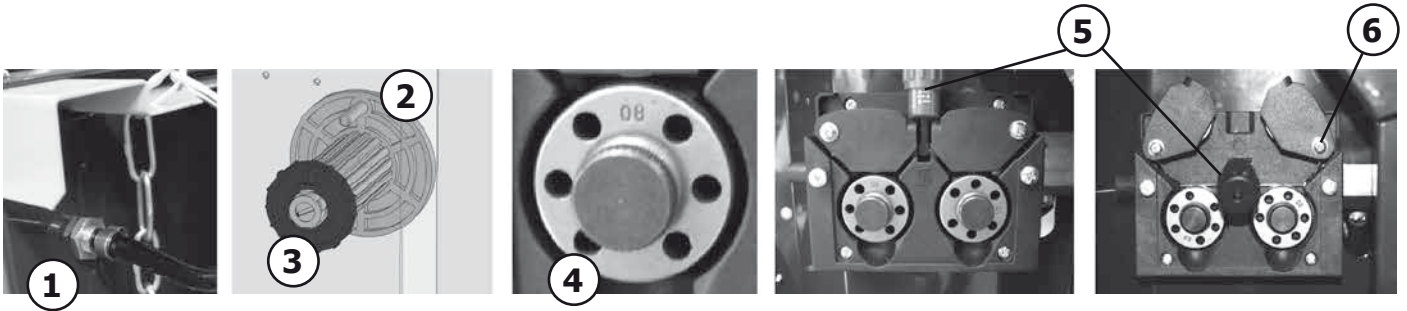

V

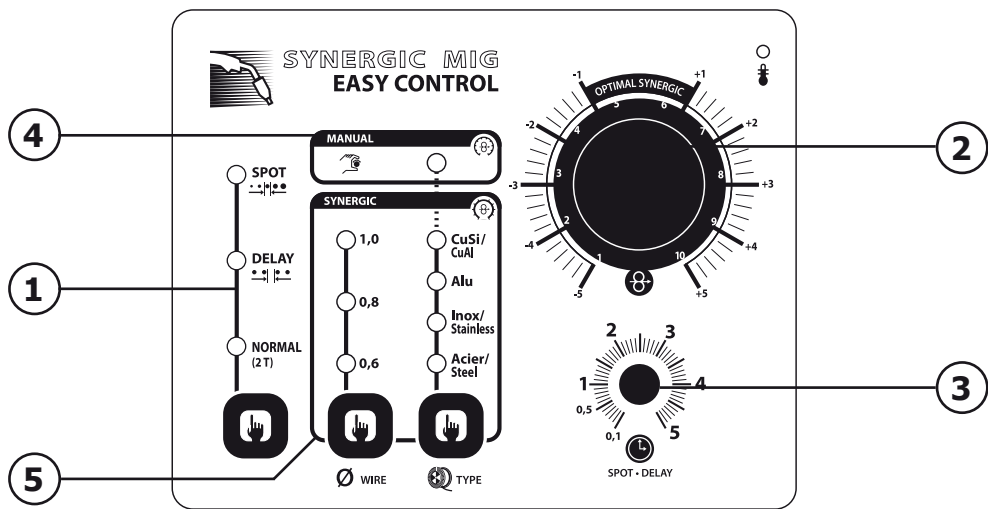

VI

SYNERGIC MODE GUIDE	ArCO ₂			Ar		Ar		CO ₂			
	Acier / Steel Inox / Stainless steel			Alu	Brazing (CuSi / CuAl)		Acier / Steel				
Ø	0,6	0,8	1	0,8	1	0,8	1	0,6	0,8	1	
mm	0,6	1	–	–	1	–	1	–	4	–	–
	0,8	2	1	–	1	–	2	–	4	4	–
	1	3	2	1	1	1	3	2	4	4	5
	2	4	4	2	2	3	–	3	5	4	5
	3	–	–	4	3	3	–	4	–	–	5
	4 +	–	–	5+	4+	4+	–	5+	–	–	6+

VII

1

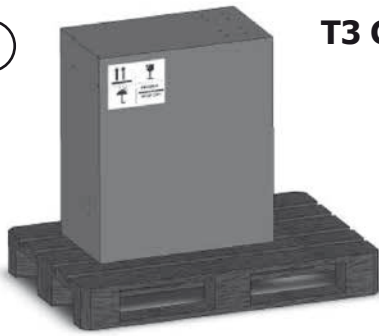

T3 GYS AUTO

2

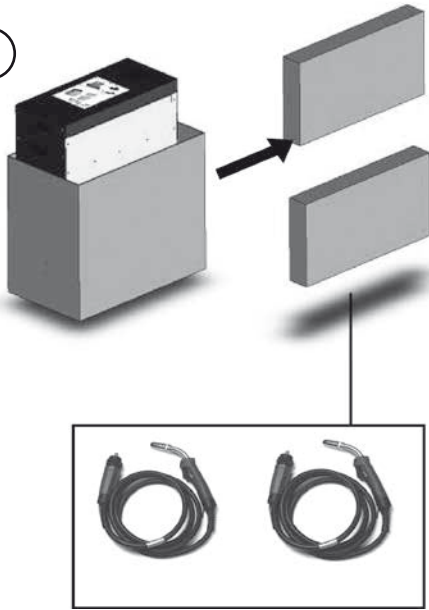

- Prémonter les vis manuellement sans les bloquer
- Pre-install the screws manually without blocking them

Vis/Screws
M5x12 (x8)

Ecrous/Nuts
M5x8 (x8)

M1 - T1 - T3 GYS AUTO

3

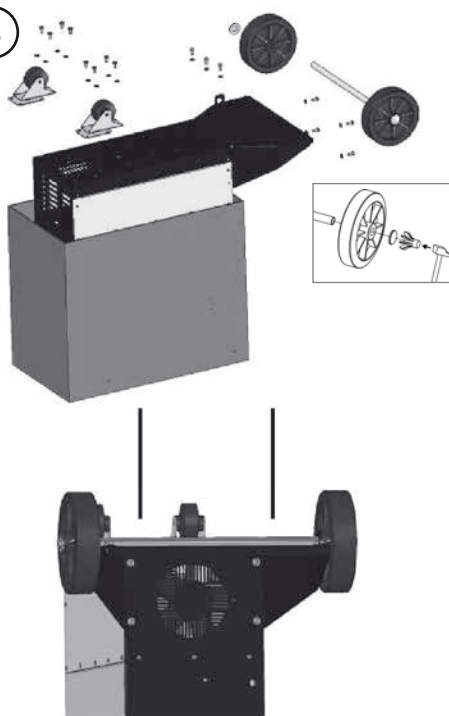

Visser toutes les vis du support bouteilles
Tighten all the screws of the gas bottle stand

4

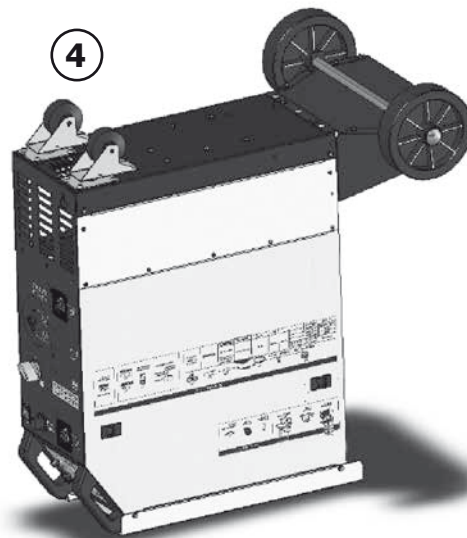

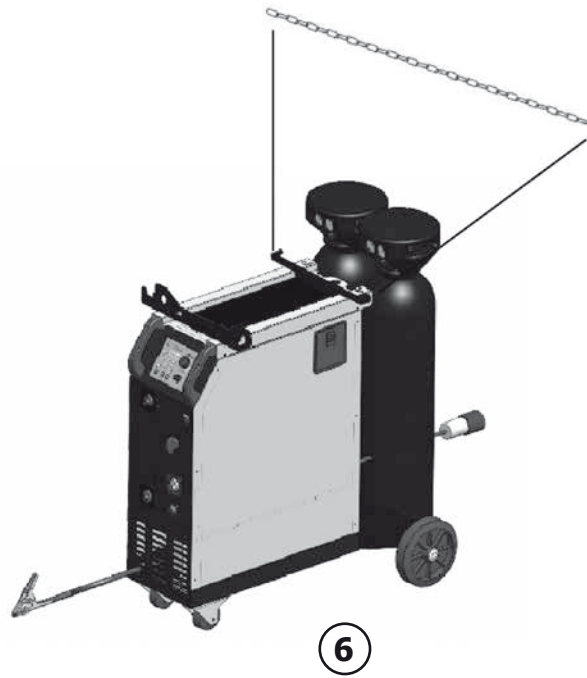
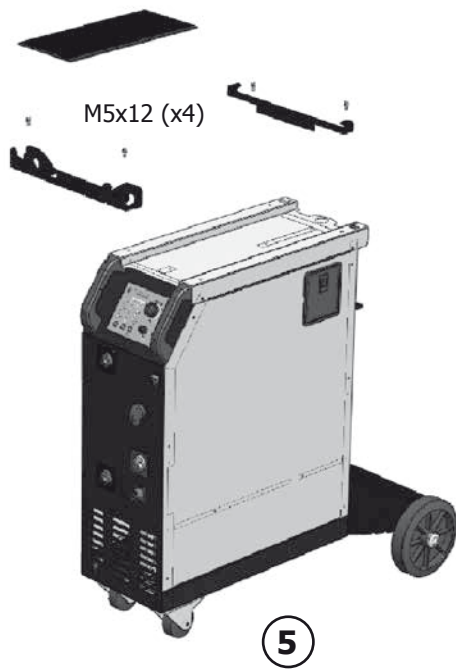

.....

T3 GYS AUTO (option ref. 032958 / 032972)

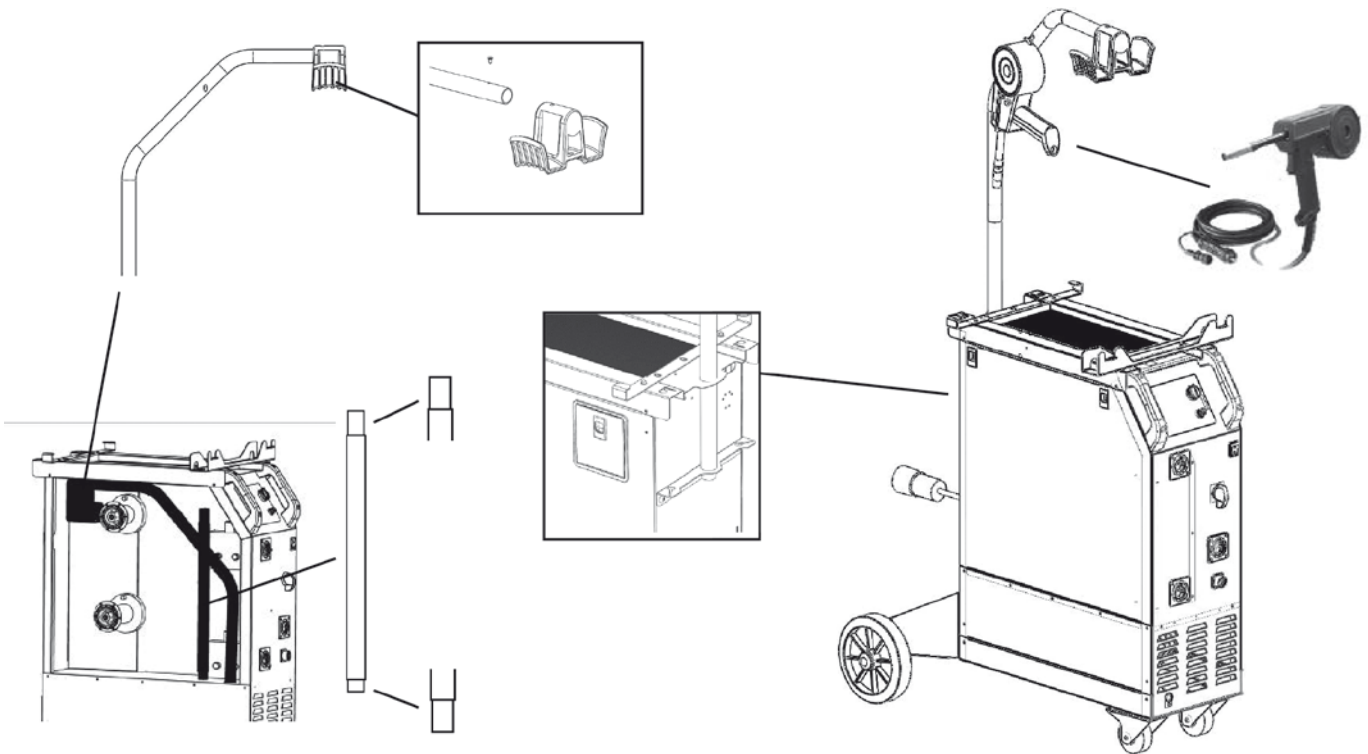

DESCRIPTION

Thank you for choosing our product! In order to take the most of your Mig welder please read the following instructions carefully:

These welding are recommended to weld steel, stainless steel, aluminium and for the "MIG Brazing" of high-tensile strength steels with CuSi and CuAl wires (ideal for car body repairs). Its adjustment is easy and fast thanks to its « synergic wire speed » function. They work on a 380V 3-phase power supply or 220V/380V 3-phase for the T1 GYS auto DV and T3 GYS auto DV. The M1 GYS AUTO works on a 230V single phase power supply.

ELECTRICITY SUPPLY

The absorbed current (I_{1eff}) is indicated on the device, for the maximum use conditions. Check that the power supply and its protections (fuse and/or circuit breaker) are compatible with the current needed at use. In some countries, it might be necessary to change the plug to allow the use at maximum conditions. The device must be placed in such way that the power socket is always accessible.

- These welding, are supplied with a 16A plug of RS-015 CEE.

- The M1 GYS AUTO has to be connected to a 230 V (50Hz) earthed power supply with a a circuit breaker 16A and 1 differential 30mA.

- The T1 GYS auto, T3 GYS auto, T1 GYS auto DV and T3 GYS auto DV have to be connected to a 380 V (50Hz) earthed power supply with a circuit breaker 10A and 1 differential 30mA. Do not use an extension cord which has a wire section inferior to 2.5 mm².

- For the T1 GYS auto DV and T3 GYS auto DV only, 220V 3-phase power supply:

this device is pre-built in 380V three-phase. If your electrical installation is in 220V 3-phase, you have to modify the connection on the terminal board. This modification has to be realized by a competent person. (see the electrical diagram at the end of the manual)

CONTROLS AND FEATURES (FIG 1 & 2)

1- switch On-Off

2- 7 positions power adjustment switch : allows adjustment of the welding voltage at the generator output. The adjustment of the output voltage is proportional to the thickness of the material to weld. (refer to page 6)

3- welding settings adjustment keyboard (manual or automatic mode)

4- European standard torch coupling

5- spool on gun coupling command

6- thermal protection light : informs when a short break is necessary following intensive use.

7- torch support

8- supply cable (2m M1GYS AUTO, 3m T1GYS, 6m T3GYS).

9- out earth cable for T1GYS and M1GYS AUTO, earth cable with a 200A clamp for T3GYS

10- gas bottles support (max 1 bottle 4m³ for M1GYS AUTO and max 2 bottles 4m³ for T1GYS, T3GYS).

11- fastening chain for bottles

12- reel support 200/300 mm

13- solenoid valve torch 1

14- torch cable support

T3GYS:

15- reel support 200 mm

16- solenoid valve torch 2

17- solenoid valve for spool gun

SEMI-AUTOMATIC WELDING FOR STEEL/STAINLESS STEEL (MAG MODE)(FIG 2)

These welding can weld 0.6/0.8 and 1.0mm steel and stainless steel wires (fig 2A). The device is capable of working with Ø 0.8 mm steel wire (contact tube Ø 0.8, roller Ø 0.6/0.8 and Ø 0.8/1.0). If you need to use Ø 0.6mm wire, you will have to change the contact tube, and ensure that the reversible rollers in the wire feeder are positioned correctly (so that the writing that states "0.6mm" is visible when in place). For Steel or Stainless Steel, you will need to use specific gas - Argon + CO₂ (Ar + CO₂). The proportion of CO₂ will vary depending on usage. The gas flow in steel is between 8 and 12L / min depending on the environment and experience of the welder. For the specific requirements, seek advice from your gas distributor.

SEMI-AUTOMATIC WELDING FOR ALUMINIUM (FIG 2)

These welding can weld 0.8 and 1mm aluminium wires (fig 2B).

To weld aluminium, neutral gas "pure argon" (AR) is required. When choosing gas, ask a gas distributor for advice. The gas flow in aluminium should be between 15 and 25 L / min depending on the environment and experience of the welder.

Things to note when welding with Aluminium:

-Set the pressure rollers of the wire feeder on the wire at the minimum pressure so as not to pinch the wire

- Remove the capillary tube before connecting the aluminium torch

- When welding aluminium use a special aluminium torch with Teflon sheath to reduce friction. Do not cut the sheath near the connector! It is used to guide the wire from the rollers. (diagram 3-B)

- Contact Tip: Use a contact tip SPECIAL aluminium corresponding to the diameter of the wire.
- Contact Tip: Use the specific Aluminium contact tip corresponding to the diameter of the wire.

SEMI-AUTOMATIC BRAZING WELDING FOR HIGH-TENSILE STRENGTH STEELS

These welding are recommended by car manufacturers to braze-weld high-tensile strength plates with a cuprosilicium CusI3 wire or cuproaluminium CuAl8 wire (Ø 0.8 mm and Ø 1 mm). The welder must use a neutral gas: pure argon (Ar). For specific gas requirements, seek advice from your gas distributor. The gas flow required s between 15 and 25 L / min.

GAS CONNECTION (FIG 3)

Connect the manometer (flowmeter) to the gas bottle (manometer not supplied with the product). For use with one or two bottles of gas.

To connect two bottles of gas to three torches, split the pipe into 3 pieces and attach a 3-way "Y" connector. (fig 3-C)

To link a single bottle of gas with 3 torches, cut the pipe into 4 pieces and attach two 3-way "Y" connectors.

Connect each bottle to the solenoid valves in the following order:

- T1 solenoid valve to the top left (fig 3B:13)
- Spool gun solenoid to the top right (fig 3B:17)
- T3 solenoid valve to the bottom (fig 3B:16)

To avoid any gas leaks, always use the collars supplied with the product.

PROCESS OF REELS AND TORCHES ASSEMBLY (FIG 4)

Open the device trapdoor.

- Place the reel on the driving pin (fig 4:2) of the reel support.
- Adjust the reel brake (fig 4:3) to avoid the reel inertia tangling the wire when welding stops. In general, do not tighten too much!
- The electrical roller (fig 4:4) is a double groove roller (0,6/ 0,8 and 0,8/1). The indication on the visible side of the roller is the diameter in use. For a 0,8 wire, use the 0,8 groove.
- For the first use:
- Release the fixing screw of the wire guide.

To set the adjusting knob of the pressing rollers (fig 4:5), proceed as follow: loosen the knob fully, start the motor by pressing the torch trigger, tighten the adjustment knob whilst pressing the trigger. Bend the wire where it comes out of the nozzle and hold it in place to stop its progress. The setting is correct when the guide roller slides over the wire even when it is blocked at the end of the torch. A common adjustment is the rollers command (fig 4:5) on the scale 3 for steel and 2 for aluminium.Nb: for the aluminium wire put a minimum pressure in order not to crush the wire.

CHOICE OF REELS

possible settings:

type fil		Torche 1 T1,T3,M1	Torche 2 T3	Spool gun T3	Gaz
acier	Ø 300	x			argon + CO2
	Ø 200	x	x		
	Ø 100			x	
inox	Ø 200	x	x		argon pur
	Ø 100			x	
CuSi3	Ø 200	x	x		argon pur
CuAl8	Ø 200	x	x		
Alu AlMg5	Ø 300	x*			
	Ø 200	x*	x*		
AlSi5	Ø 100			x	
AlSi12	Ø 100			x	

CuSi3: Recommendation OPEL & MERCEDES

CuAl8: Recommendation Peugeot/Citroën/Renault

AlSi12: Recommendation for automotive aluminium from metal sheet of 0,6mm to 1,5 mm of thickness.

* Consider Teflon sheath and special aluminium contact tip

«MANUAL» MODE (FIG 5)

1-welding mode choice:

- Normal (2T): standard two-stage welding
- Delay: intermittent welding modes for an optimised operating procedure.
- Spot:spotwelding with ajustable spot diameter

2- Wire speed settings: wire speed fitting potentiometer. The speed varies from 1 to 15L/minute.

3- Spot/delay potentiometer fitting

4- Manual mode: In manual mode, the wire speed is determined by the user by adjusting the potentiometer (2).

5- Synergic mode: position the potentiometer (2) in the middle of the «optimal synergic» zone. In this mode, the device determines the optimal wire speed according to 3 parameters:

- Voltage
- Wire diameter
- The power mode.

It's possible to adjust the wire speed +/-.

In position Normal(2T), 2 modes are proposed to ease the settings of the device: Manual or Synergic.

«MANUAL» MODE (FIG 5)

To set your device, proceed as follow:

- Choose the welding voltage using the 7 positions switch
- Example: position 1 for 0,6mm metal sheets and position 7 for 4 mm metal sheets.
- Adjust the wire speed with the potentiometer(2).

Advice:

The wire speed adjustment is often determined « with the noise »: the arc must be stable and have a low crackling. If the speed is too low, the arc is not continuous. If the speed is too high, the arc crackles and the wire pushes back the torch.

«SYNERGIC» MODE (FIG 5)

This function will set the wire speed automatically.

For this:

Position the wire speed potentiometer (2) in the middle of the« Optimal synergic » zone.

-Select:

-The wire type (5)

-The wire diameter (5) The power mode (7 position switch), to select the right position in accordance with the thickness of the part to weld, please refer to the table (fig 6)

From this combination, they determines the optimal wire speed and the device is ready to weld. It is also possible to adjust the wire speed if necessary by adjusting potentiometer (2) + or – manually. A memory of the last welding configuration is done (wire diameter, wire type, mode).

GAS choice (only for steel welding) :

In synergic mode, it's determines the welding settings in accordance with the gas used. By default, in steel welding the machine is set in « Argon + CO2 ».

To change the gas and set the machine in CO2 mode or come back in Argon + CO2 mode, process as explained:

1-Press « Type » for 5 seconds until the keyboard switches off the release.

2-Within 5 seconds, choose the required setting with the key « choose mode ».

-Normal (2T) => Argon + CO2 (default setting)

-Delay => CO2 100%

3-The confirmation is done either by the « Type » key, or by waiting for 5 seconds.

4-Once confirmed, the machine reverts to the normal functioning mode but the modification is registered even when the machines is switched off.

SPOT MODE (FIG 5)

This function allows spot welding. To adjust the length of each spot, use the potentiometer (3).

DELAY MODE (FIG 5)

Allows intermittent welding, the delay can be adjusted through the potentiometer (3).

This function allows welding very thin steel or aluminium metal sheet, limiting the risk of piercing and distortion (especially for aluminium welding).

SPOOL GUN (OPTION)

Spool gun description and functioning

- The spool on gun torch must be installed on the torch T1 connector.
- The spool on gun works either in « Manual » mode or either in « Synergic » mode.
- In « manual » or « Synergic » mode, only the wire speed adjustment knob on the torch (4) is active (the wire speed potentiometer of the device is not active).
- « Synergic » mode:
- Place the wire speed knob on the torch (4) at the middle of its area then adjust if necessary.
- For more information on the « Synergic » mode, refer to page 9.

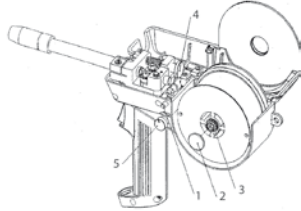

- 1- Hood Opening/closing knob
- 2- Reel holding nut
- 3- Reel locknut (do not tighten too much)
- 4- Rollers tension adjusting screw
- 5- Wire speed adjusting knob

Assembly process

Reel :

- Open the hood (1)
- Remove the reel holding nut (2) (NB. : no reversed screw)
- Tighten the locknut (3) to bulge the reel axis (do not tighten too much)
- Insert the reel-To insert the wire in the rollers, apply pressure on the «roller tension setting screw »

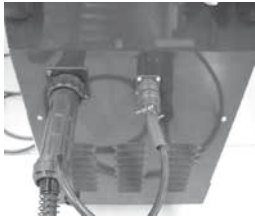

Torch:

- Pull out the wire of the T1 torch in winding up the reel.
- Pull out the T1 torch
- Plug the power connector of the spool on gun on the T1 connector.
- Plug the control connector of the spool gun-Place the switch on T1 position.

FACTEUR DE MARCHEDUTY CYCLE AND WELDING ENVIRONMENT

- The welding unit describes an output characteristic of «constant current» type. The duty cycles following the norm EN60974-1 (at 40°C on a 10mn cycle) are indicated in the table here below:

X/60974-1 à 40°C(T cycle=10min)	I max	60%(T cycle=10min)	100%(T cycle=10min)
T1 GYS AUTO	25% à 150A	110A	90A
T3 GYS AUTO	25% à 150A	110A	90A
M1 GYS AUTO	15% à 140A	80A	60A

Note: The warming test was done at room temperature and the duty cycle at 40°C were determinated by simulation.











- These are A-class devices. They are designed to be used in an industrial or professional environment. In a different environment, it can be difficult to ensure electromagnetic compatibility, due to conducted disturbances as well as radiation.

- This device complies with IEC 61000-3-12, provided that the power of the short-circuit Ssc is equal to or greater than 1.8MVA at the interface between the machine and the mains power network. It is the responsibility of the installer or user of the equipment to ensure if necessary by consulting the operator of the mains electricity, that the equipment is only connected to a power supply where the power of short-circuit ssc is equal to or greater than 1.8MVA.











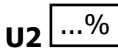



ADVICE AND THERMAL PROTECTION

- Respect the basic rules of welding.
- Leave the air holes of the device open to allow air circulation.
- Leave the device plugged after welding to allow its cooling.
- Thermal protection: The light turns on and the cooling duration is a couple of minute according to the area temperature.





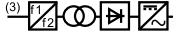

ICONES / SYMBOLS / ZEICHENERKLÄRUNG / ICONOS / СИМВОЛЫ

A	Ampères - Amps - Ampere - Amperios - Ампер
V	Volt - Volt - Volt - Voltios - Вольт
Hz	Hertz - Hertz - Hertz - Hertz - Герц
	Soudage MIG/MAG (MIG: Metal Inert Gas / MAG: Metal Active Gas) - MIG/MAG Welding (MIG: Metal Inert Gas / MAG: Metal Active Gas) - MIG/MAG Schweißen (MIG: Metal Inert Gas/ MAG: Metal Active Gas) - Soldadura MIG/MAG (MIG: Metal Inert Gas / MAG: Metal Active Gas) - Полуавтоматическая сварка MIG/MAG (MIG: Metal Inert Gas / MAG: Metal Active Gas)
	Soudage à l'électrode enrobée (MMA – Manual Metal Arc) - Electrode welding (MMA – Manual Metal Arc) - Schweißen mit umhüllter Elektrode (E-Handschweißen) - Soldadura con electrodos revestidos - Ручная дуговая сварка
	Soudage TIG (Tungsten Inert Gaz) - TIG welding (Tungsten Inert Gas) - TIG (WIG) Schweißen (Tungsten Inert Gas) - Soldadura TIG (Tungsten Inert Gas) - Сварка TIG (Tungsten Inert Gas)
	Convient au soudage dans un environnement avec risque accru de choc électrique. La source de courant elle-même ne doit toutefois pas être placée dans de tels locaux. - Adapted for welding in environment with increased risks of electrical shock. However, the welding source must not be placed in such places. - S-Zeichen: Das Schweißen unter beengten Verhältnissen ist mit diesen Schweißgeräten zugelassen.- Adaptado a la soldadura en un entorno que comprende riesgos de choque eléctrico. La fuente de corriente ella misma no debe estar situada dentro de tal locales. - Адаптирован для сварки в среде с повышенным риском электрошока. Однако сам источник питания не должен быть расположен в таких местах.
IP21	Protégé contre l'accès aux parties dangereuses avec un doigt, et contre les chutes verticales de gouttes d'eau. - Protected against rain and against fingers access to dangerous parts. - Schutz gegen Berührung mit den Fingern und mittelgroße Fremdkörper, Schutz gegen Tropfwasser. - Protegido contra el acceso a las partes peligrosas con los dedos, y contra las caídas verticales de gotas de agua. - Аппарат защищен от доступа рук в опасные зоны и от вертикального падения капель воды Сварка на постоянном токе.
IP23	Protégé contre l'accès aux parties dangereuses des corps solides de diam>12,5mm et chute d'eau (30% horizontal) - Protected against access to dangerous parts by any solid body which Ø > 12,5mm and against water falls (30% horizontal) - Gegen Eindringen von Körpern mit einem Durchmesser > 12,5mm und gegen Sprühwasser geschützt (Einfallwinkel 30% horizontal) - Protegido contra el acceso a las partidas peligrosas de cuerpos solidos de diametro >12.5mm y las caídas de agua (30% horizontal) - Защищен против доступа твердых тел диаметром >12,5мм к опасным частям и от воды (30% горизонт.)
	Courant de soudage continu - Welding direct current - Gleichschweißstrom - La corriente de soldadura es continua - Сварка на постоянном токе
	Courant de soudage alternatif - Welding alternative current - Wechselstromschweißen - Corriente de soldadura alterna - Переменный сварочный ток
	Alimentation électrique triphasée 50 ou 60Hz. - Three-phase power supply 50 or60Hz. - Dreiphasige Netzversorgung mit 50 oder 60Hz. - Alimentación eléctrica monofásica 50 o 60Hz. - Трехфазное напряжение 50 или 60Гц.
	Alimentation électrique monophasée 50 ou 60Hz - Single phase power supply 50 or 60Hz - Einphasige Netzversorgung mit 50 oder 60Hz - Alimentación eléctrica monofásica 50 o 60 Hz - Однофазное напряжение 50 или 60Гц
U0	Tension assignée à vide. - Rated no-load voltage. - Leerlaufspannung. - Tensión asignada de vacío. - Напряжение холостого хода.
U1	Tension assignée d'alimentation - rated supply voltage - Netzspannung - Tensión de la red - Напряжение сети
I1max	Courant d'alimentation assigné maximal (valeur efficace) - Rated maximum supply current (effective value) - Maximaler Versorgungsstrom (Effektivwert) - Corriente máxima de alimentación de la red - Максимальный сетевой ток (эффективная мощность)
I1eff	Courant d'alimentation effectif maximal - Maximum effective supply current - Maximaler tatsächlicher Versorgungsstrom - Corriente de alimentación efectiva máxima - Максимальный эффективный сетевой ток
EN60 974-1	L'appareil respecte la norme EN60974-1 - The device complies with EN60974-1 standard relative to welding units - Das Gerät entspricht der Norm EN60974-1 für Schweißgeräte - El aparato está conforme a la norma EN60974-1 referente a los aparatos de soldadura - Аппарат соответствует европейской норме EN60974-1
	Transformateur-redresseur triphasée. - Three-phase converter-rectifier. - Dreiphasiger Trafo/Frequenzumwandler. - Transformador-rectificador trifásico. - Трехфазный инвертор, с трансформацией и выпрямлением.
	Transformateur-redresseur monophasé. - Rectifier-Single-phase converter - Einphasiger Trafo/Frequenzumwandler - Transformador-rectificador monofásico - однофазный инвертор, с трансформацией и выпрямлением.
X(40°C)	Facteur de marche selon la norme EN 60974-1 (10 minutes – 40°C). - Duty cycle according to the standar EN 60974-1 (10 minutes – 40°C). - Einschaltdauer gemäß EN 60974-1 (10 Minuten – 40°C). - Factor de marcha según la norma EN 60974-1 (10 minutos – 40°C). - ПВ% по норме EN 60974-1 (10 минут – 40°C).
I2 ...%	I2: courant de soudage conventionnel correspondant. - I2: corresponding conventional welding current. - I2: entsprechender Schweißstrom. - I2: Corrientes correspondientes. - I2: Токи, соответствующие X*

ICONES / SYMBOLS / ZEICHENERKLÄRUNG / ICONOS / СИМВОЛЫ

	U2: Tensions conventionnelles en charges correspondantes. - U2: conventional voltages in corresponding load. - U2: entsprechende Arbeitsspannung. - U2: Tensiones convencionales en carga. - U2: соответствующие сварочные напряжения*.
	Appareil conforme aux directives européennes. - The device complies with European Directive. - Gerät entspricht europäischen Richtlinien. - El aparato está conforme a las normas europeas. - Устройство соответствует европейским нормам.
	Conforme aux normes GOST (Russie). - Conform to standards GOST / PCT (Russia). - in Übereinstimmung mit der Norm GOST/PCT. - Conforme a la normas GOST (PCT) (Rusia). - Продукт соответствует стандарту России (PCT).
	L'arc électrique produit des rayons dangereux pour les yeux et la peau (protégez-vous !). - The electric arc produces dangerous rays for eyes and skin (protect yourself !). - Der elektrische Lichtbogen verursacht Strahlungen auf Augen und Haut (Schützen Sie sich !). - El arco produce rayos peligrosos para los ojos y la piel (¡ Protéjase !). - Электрическая дуга производит опасные лучи для глаз и кожи (защитите себя!). - Внимание! Сварка может вызвать пожар или взрыв.
	Attention, souder peut déclencher un feu ou une explosion. - Caution, welding can produce fire or explosion. - Achtung! Schweißen kann Feuer oder Explosion verursachen. - Cuidado, soldar puede iniciar un fuego o una explosión. - Внимание! Сварка может вызвать пожар или взрыв.
	Attention ! Lire le manuel d'instruction avant utilisation. - Caution ! Read the user manual. - Achtung! Lesen Sie die Betriebsanleitung. - Cuidado, leer las instrucciones de utilización. - Внимание ! Читайте инструкцию по использованию.
	Produit faisant l'objet d'une collecte sélective- Ne pas jeter dans une poubelle domestique. - Separate collection required, Do not throw in a domestic dustbin. - Für die Entsorgung Ihres Gerätes gelten besondere Bestimmungen (Sondermüll). Es darf nicht mit dem Hausmüll entsorgt werden. - Este aparato es objeto de una recolección selectiva. No debe ser tirado en un cubo doméstico. - Продукт требует специальной утилизации. Не выбрасывать с бытовыми отходами.
	Système de refroidissement par liquide - Liquid cooling system - Wasserkühlgerät - Sistema de refrigeración por líquido - Система охлаждения жидкостью
P 1l/min... kW	Puissance de refroidissement assignée à un débit de volume de 1l/min à 25°C - Cooling power indicated by volumetric flow of 1l/min at 25°C - Kühlleistung : Volumenstrom von 1l/min bei 25°C - Potencia de refrigeración asignada a un caudal de volumen de 1l/mn con 25°C - Номинальная мощность охлаждения/расход объемом 1л/мин при 25°C
p max... MPa (bar)	Pression maximale - Maximum pressure - Maximaldruck MPa - Presión máxima (bar) - Максимальное давление (Бар)
	Fusible pour le groupe de refroidissement - Fuse for the liquid cooling system - Sicherung des Wasserkühlgerätes - Fusible para el grupo de refriregación - Плавкий предохранитель для кулера
	Entrée du liquide de refroidissement - Coolant input - Wasservorlauf - Entrada del líquido de refrigeración - Вход охлаждающей жидкости
	Sortie du liquide de refroidissement - Coolant output for torch - Wasserrücklauf - Salida del líquido de refrigeración - Выход охлаждающей жидкости
	Information sur la température (protection thermique) - Temperature information (thermal protection) - Information zur Temperatur (Thermoschutz) - Información de la temperatura (protección térmica) - Информация по температуре (термозащита)
	Source de courant de technologie onduleur délivrant un courant CA/CC - Inverter technology power supply delivers a CA/CC current - Eine Stromquelle, ausgestattet mit der Invertertechnologie, die Gleich- und Wechselstrom erzeugen kann. - Fuente de corriente de tecnología ondulador liberando una corriente CA/CC - Источник тока с технологией преобразования, выдающий переменный и постоянный ток
	Ventillé - Ventilated - Lüfter - Ventilado - Содержит встроенный вентилятор
	Le dispositif de déconnexion de sécurité est constitué par la prise secteur en coordination avec l'installation électrique domestique. L'utilisateur doit s'assurer de l'accessibilité de la prise. - The mains disconnection mean is the mains plug in combination with the house installation. Accessibility of the plug must be guaranteed by user. - Die Stromunterbrechung erfolgt durch Trennen des Netzsteckers vom häuslichen Stromnetz. Der Gerätanwender sollte den freien Zugang zum Netzstecker immer gewährleisten - El dispositivo de desconexión de seguridad se constituye de la toma de la red eléctrica en coordinación con la instalación eléctrica doméstica. El usuario debe asegurarse de la accesibilidad del enchufe. - Система отключения безопасности включается через сетевую штепсельную розетку соответствующую домашней электрической установке. Пользователь должен убедиться, что розетка доступна
+	Identification polarité positive - Positive pole - Pluspol - Polaridad positiva - положительная полярность

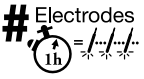
ICONES / SYMBOLS / ZEICHENERKLÄRUNG / ICONOS / СИМВОЛЫ

-	Identification polarité négative - Negative pole - Minuspol - Polaridad negativa - отрицательная полярность
	Terre - Earth ground - Erdung - Tierra - Заземление
	Ne pas utiliser en zones résidentielles (CEM) - Not for use in residential areas (EMC) - Nicht für die Benutzung in Wohnräumen geeignet. (EMV) - No usar en areas residenciales (CEM). - не использовать в жилой зоне
	Pour une utilisation en intérieur uniquement - For interior use, do not expose to the rain - Vor Nässe und Feuchtigkeit schützen! - Para un uso en interior, no exponer a la lluvia. - Использовать в помещении – не выставлять под дождь.
	Mise en veille/mise en marche - standby/On - Schalter Bereit/Ein - standby/puesta en marcha - Включить/Режим ожидания
	Nombre d'électrodes normalisées soudables en 1 heure, à 20°C, avec un temps d'arrêt de 20 s. entre chaque électrode - Number of standardized electrodes weldable during 1 hour at 20°C, with a delay of 20 s. between each electrode. - Anzahl der Standard-Elektroden, die in 1 Stunde bei 20°C geschweißt werden können mit einer Pause von 20 s zwischen jeder Elektrode - Cantidad de electrodos normalizados soldables en 1 hora, a 20°C, incluyendo una parada de 20 seg. entre cada electrodo - Количество стандартных электродов использованных за 1 час при 20°C с 20-ти секундными перерывами между электродами.
	Ces appareils à usage professionnel, classe A, sont destinés à être connectés à des réseaux privés raccordés au réseau public d'alimentation seulement en moyenne et haute tension. Il ne sont pas prévus pour être utilisés dans un site résidentiel où le courant électrique est fourni par le système public d'alimentation basse tension. Il peut y avoir des difficultés potentielles pour assurer la compatibilité électromagnétique des ces sites, à cause de perturbations conduites aussi bien que rayonnées. Classe B : Appareil prévu pour une utilisation dans un environnement «résidentiel». - Class A equipment for professional use, to be connected onto private low-voltage power supply system. Restriction to connect it to the public low-voltage power supply system: read the paragraph POWER SUPPLY – START UP. - Professionelle Klasse A Geräte: Problemloser Anschluss an ein privates Niederspannungs- Versorgungsnetz. Einschränkungen beim Anschluss an ein öffentliches Niederspannungs- Versorgungsnetz: Für weitere Informationen s. Abschnitt «Netzanschluss-Inbetriebnahme». - Estos aparatos de uso profesional, clase A, están destinados a conectarse a la red pública de alimentación solamente en tensión media y alta. No son para utilizarse en zonas residenciales cuya corriente eléctrica está suministrada por el sistema público de alimentación de baja tensión. Se puede encontrar dificultades potenciales para asegurar la compatibilidad electromagnética de estas zonas, a causa de perturbaciones conducidas tan bien como radiadas. Clase B: aparatos previstos para un uso en un entorno «residencial» - Аппарат для профессионального использования, класса А, может быть подключен к стандартной (домашней) сети, соединенной с городской электросети только среднего и высокого напряжения. Он не предусмотрен для использования в жилых кварталах со стандартной сетью питания низкого напряжения. В таких районах могут возникнуть сложности, связанные с электромагнитной совместимостью из-за кондуктивных и излучаемых помех. Класс Б: устройство может быть использовано в жилой районах.
	Commande à distance - Remote control - Fernsteuerung - Mando a distancia - Дистанционное управление
Thermal Class H	Classe d'isolation (H = 180°C) - Insulation class (H=180°C) - Isolierstoffklasse (H=180°C) - Clase de aislamiento (H=180°C) - Класс нагревостойкости изоляции (H=180°C)

Ce document est la propriété de

JBDC
134 boulevard de Loges
53941 Saint-Berthevin
FRANCE

Nicolas BOUYGUES
Président Directeur Général
